

Clarke Energy®

A **KOHLER** COMPANY

Engineer - Install - Maintain

Chris Hayton
Clarke Energy USA Inc.
Business Development Director





Agenda

- 1 **Clarke Energy**
- 2 **INNIO Jenbacher Gas Engines**
- 3 **Greenhouse Specific Applications**
- 4 **Greenhouse References**

Clarke Energy – Our Capabilities

Clarke Energy

- Established 1989 in UK as an engine service company
- Group headquarters in Liverpool, England
- Acquired by Kohler Co. in 2017
- INNIO Jenbacher Gas Engines distributor in 25 countries
 - 7GW_e installed globally
 - 155MW_e in US states
- Continuing growth:
 - \$480m in 2017
 - \$390m in 2016
 - \$300m in 2015
- >1,200 employees worldwide
- Waukesha, WI – US sales, projects and accounts
- Crown Point, IN – US Service Center
- ISO9001 Quality, ISO14001 Environment and OHSAS 18001 Health & Safety



Global Footprint

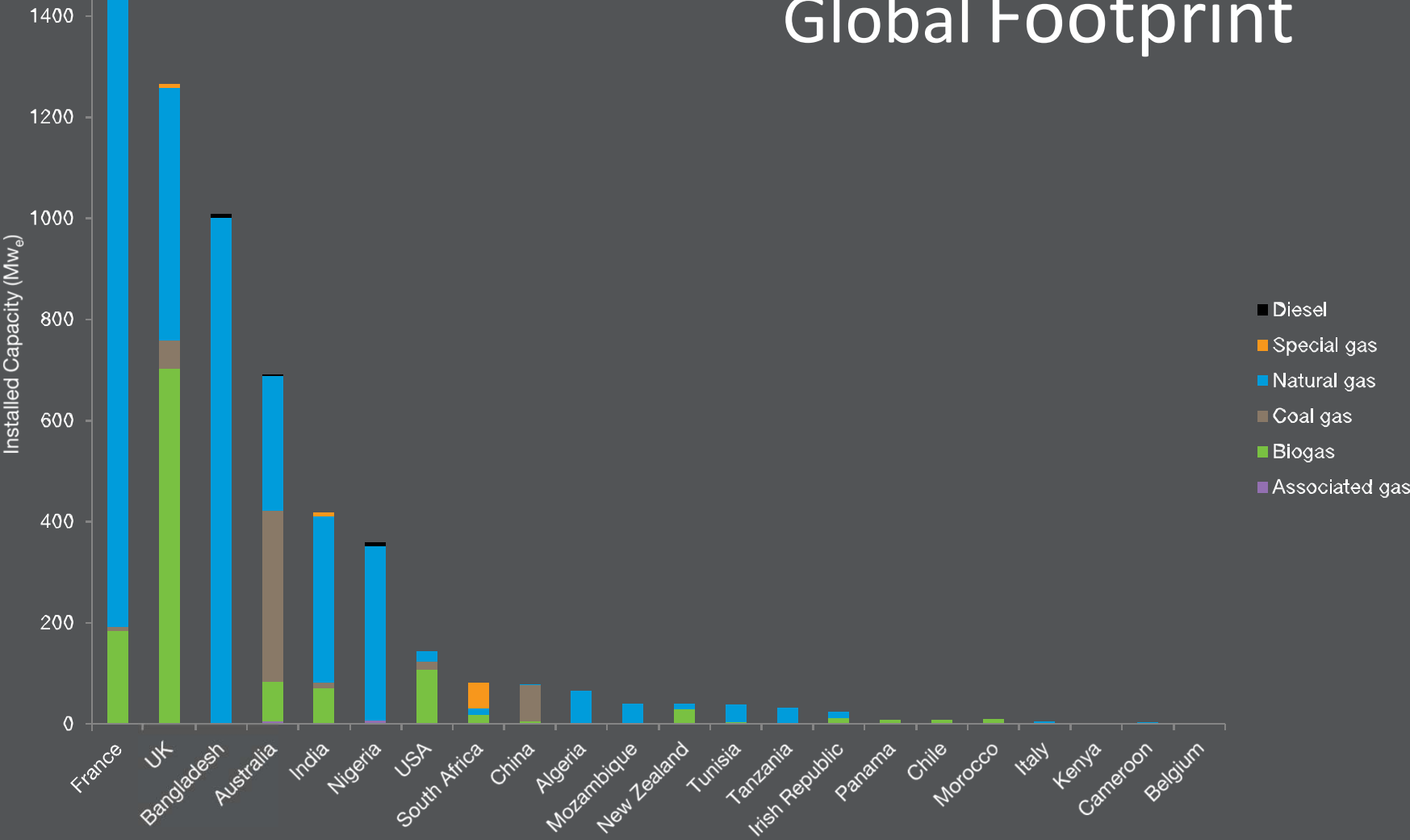

Clarke Energy provides customers of all types the ability to generate reliable, sustainable power whenever and wherever it is needed



Greenhouse

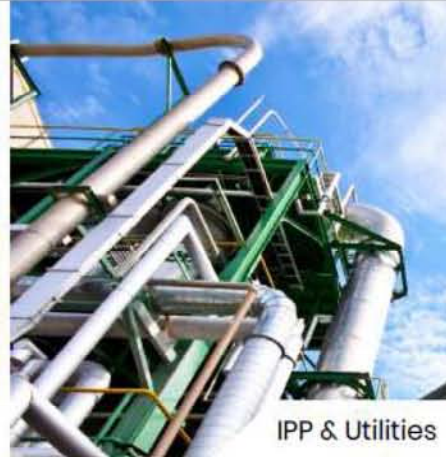

IPP & Utilities



Oil & Gas



Grid firming



Steel



**Agriculture &
Food Processing**



**Renewable
Energy**



Waste-to-Pow er



**Commercial &
Industrial Buildings**



Jenbacher and Waukesha Gas Engines



Jenbacher Gas Engines

- 22,000 engines delivered in over 80 countries
- More than 25,000MW_e installed worldwide
- Power range from 0.25MW_e to 9.5MW_e
- Electrical efficiencies up to 49.9%
- Complete gas engines – not diesel derived units
- Headquartered in Jenbacher, Austria, the business also has primary operations in Welland, Ontario and Waukesha, Wisconsin.

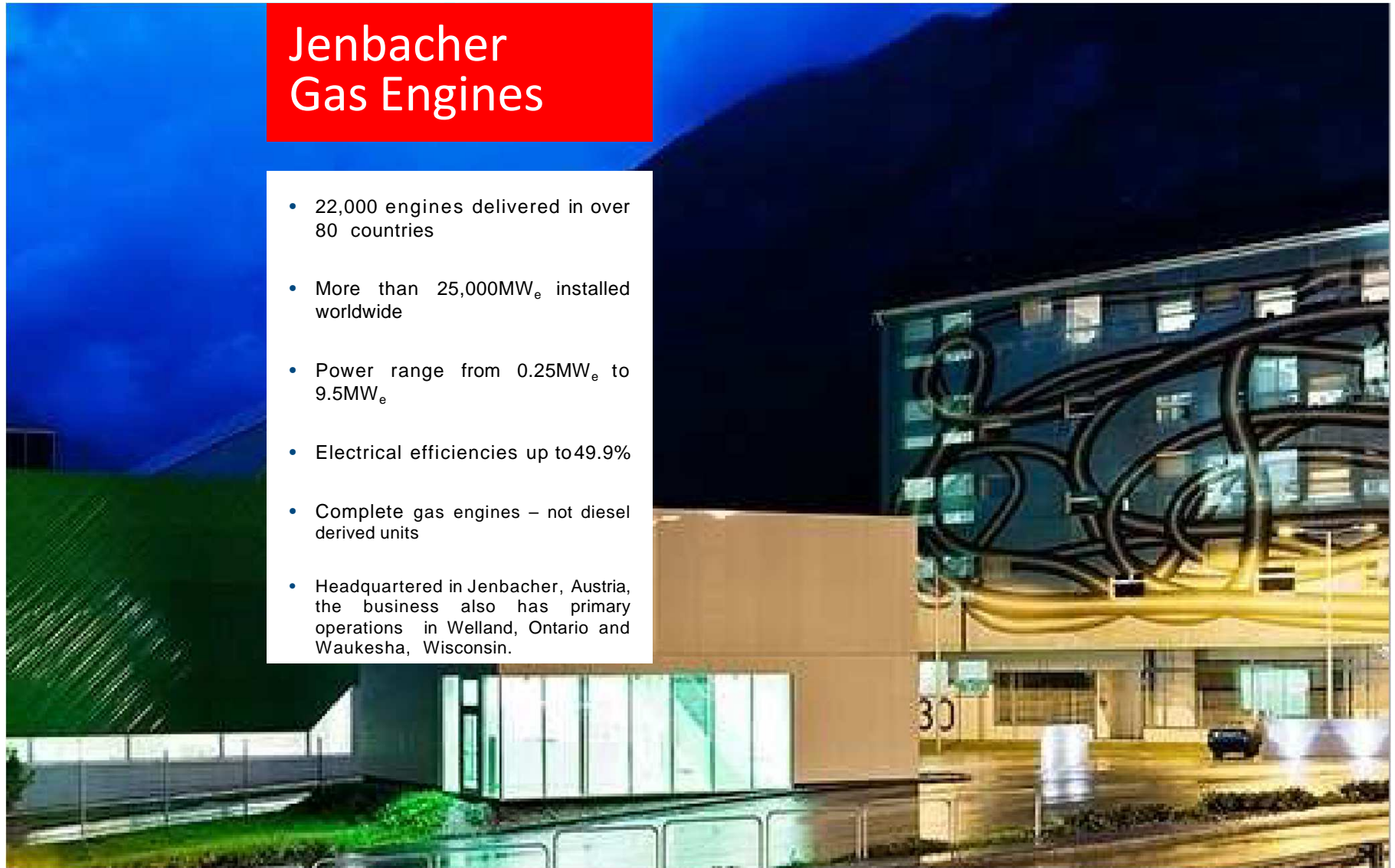

De-centralized Power Generation & CHP Product Portfolio



Jenbacher* Type 2

- / Electrical output: 249 - 330 kWe (50 Hz), 335 kWe (60 Hz)
- / V cylinder: 1500 rpm (50 Hz), 1800 rpm (60 Hz)
- / Launched in 1976



Jenbacher* Type 3

- / Electrical output: 526 - 1,067 kWe (50 Hz), 633 - 1,062 kWe (60 Hz)
- / V12, V16 and V20 cylinder: 1,500 rpm (50 Hz), 1,800 rpm (60 Hz)
- / Introduced in 1988



Jenbacher Type 4

- / Electrical output: 845 - 1,500 kWe (50 Hz), 850 - 1,426 kWe (60 Hz)
- / V12, V16 and V20 cylinder: 1,500 (50 Hz), 1,800 rpm (60 Hz)
- / launched in 2002



Jenbacher Type 6

- / Electrical output: 1,820 - 4,498 kWe (50 Hz), 1,795 - 3,011 kW (60 Hz)
- / V12, V16 and V20 cylinder; 1,500 rpm
- / Since 1989 part of the product portfolio



Jenbacher Type 9

- / Electrical output: 10.38 MWe (50 Hz), 9.35 MWe (60 Hz)
- / V20 cylinder; 1000/900 rpm
- / Electrical Efficiency:
 - / (50 Hz): 49.1 / >90%
 - / (60 Hz): 49.9 / >90%

CHP for Green House Applications



The Green House Concept

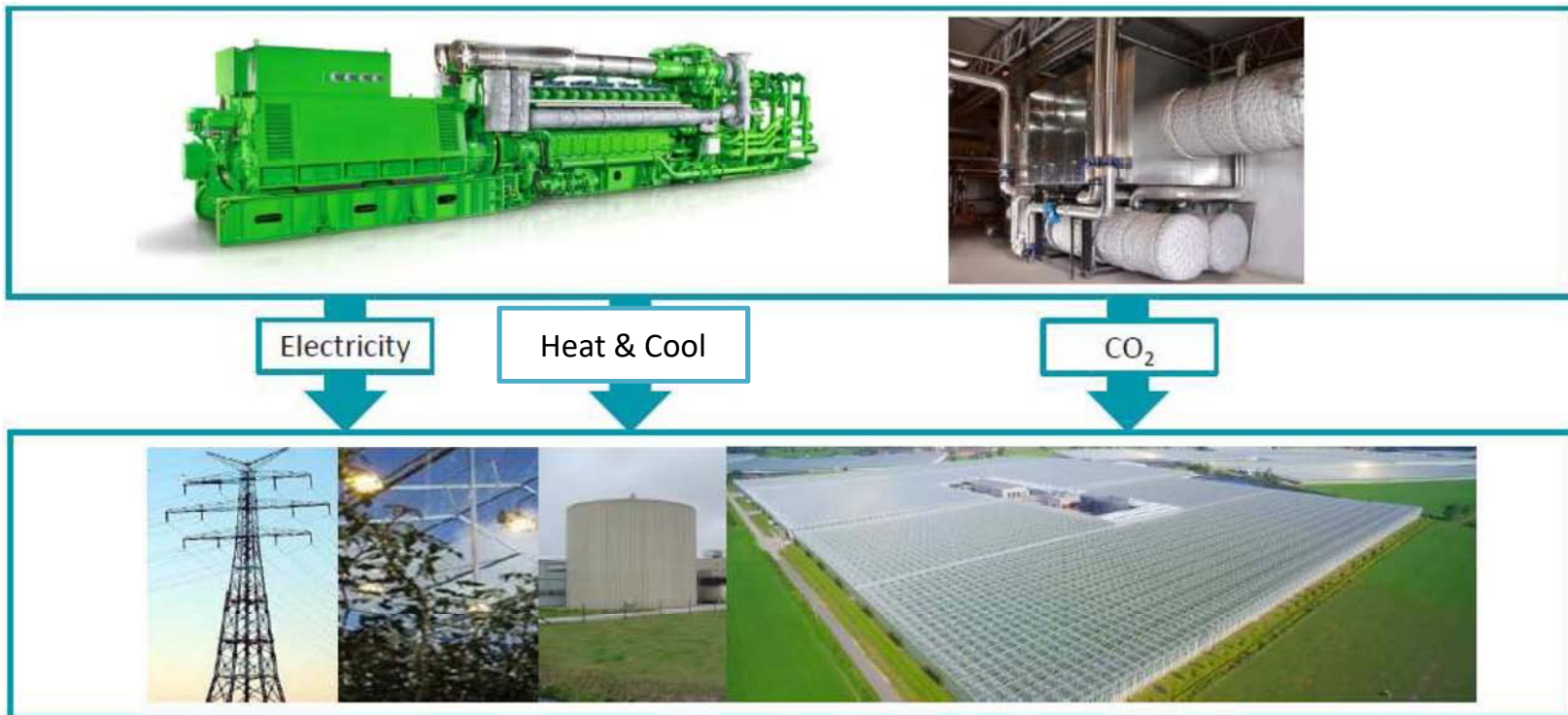

Attractive CHP in greenhouses

Simultaneous supply of heat, electricity and CO₂ with total efficiency > 90% at 100% utilization of heat

Ultra-low emissions. NO_x, CO, C₂H₄ reduced for CO₂ for usage in greenhouse plant fertilization



Influence of CO₂ vs. crop production

It is possible to raise the CO₂ level in the greenhouse twice as high in comparison to a conventional boiler with the same heat output using an exhaust gas cleaning system in combination with our gas engine. This way the positive influence on the crop production can add up to 30% or even more!

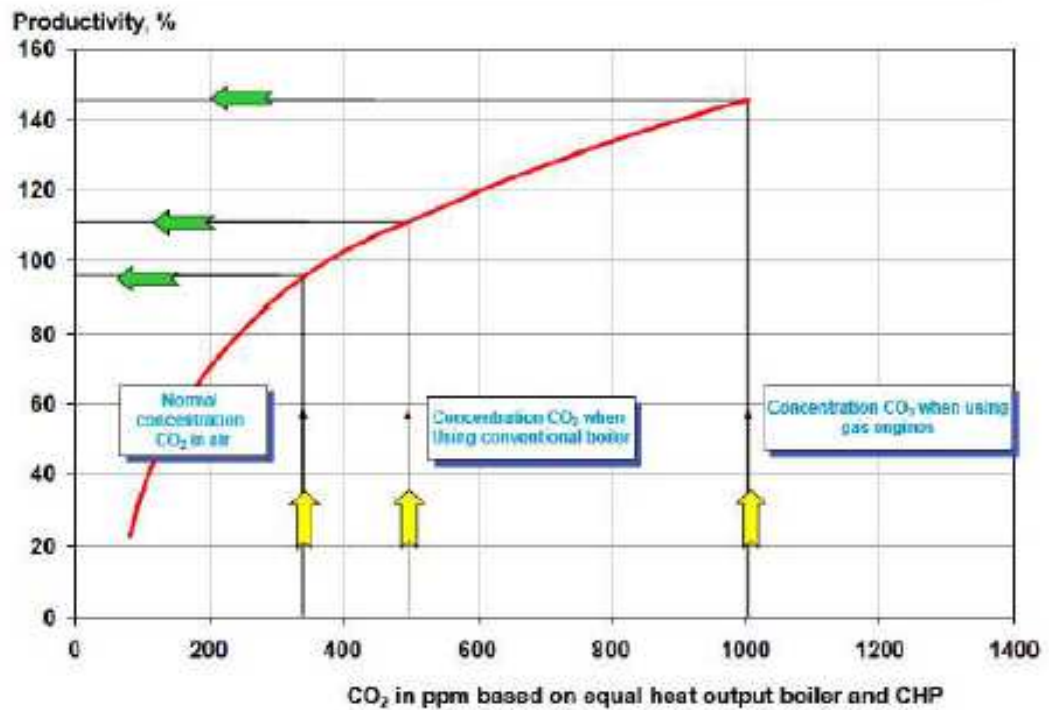

Exhaust Gas Cleaner Tech'

Selective Catalytic NOx Reduction (SCR)

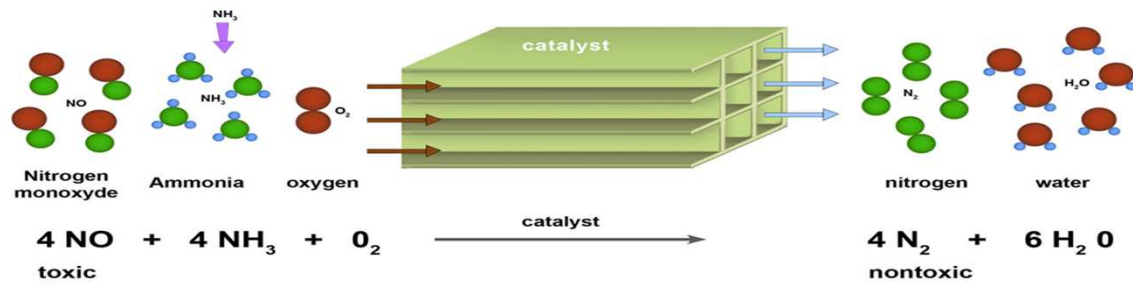

Catalytic CO & HC Oxidation (Oxy' Cat')

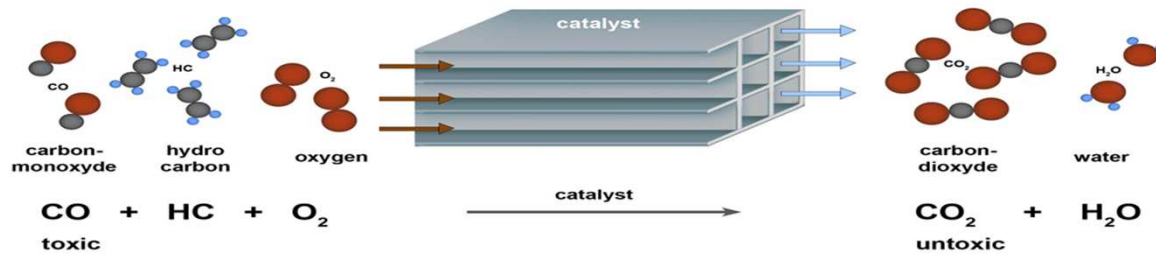

The greenhouse concept

Combined heat, power and CO₂

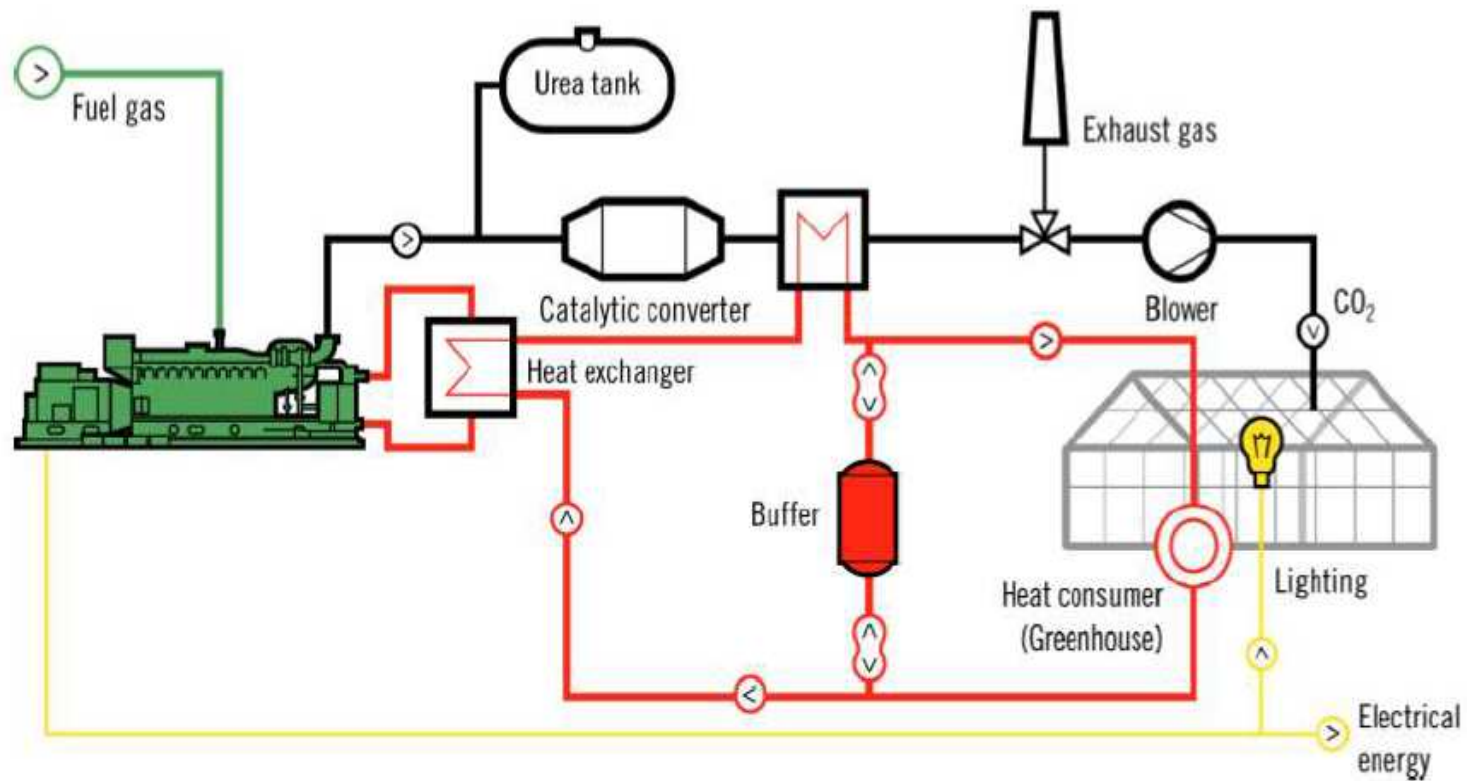

Absorption Chiller Principle of Operation

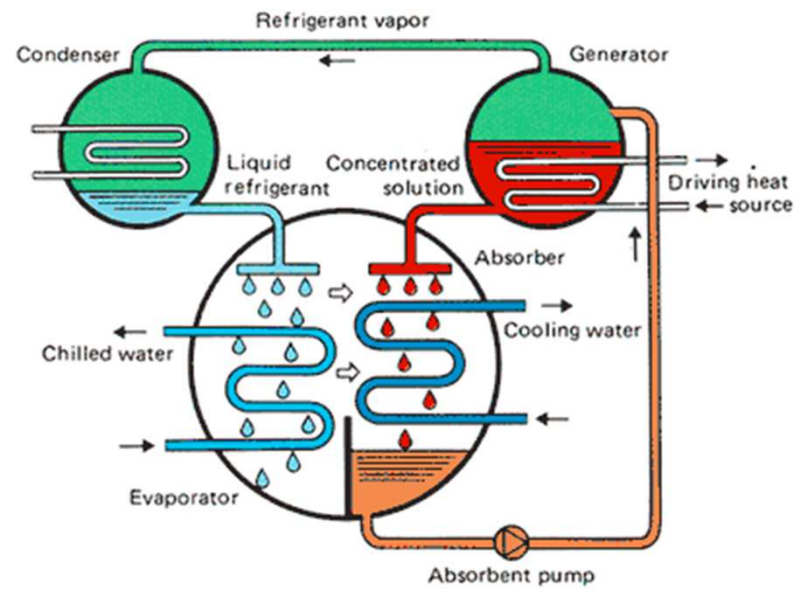

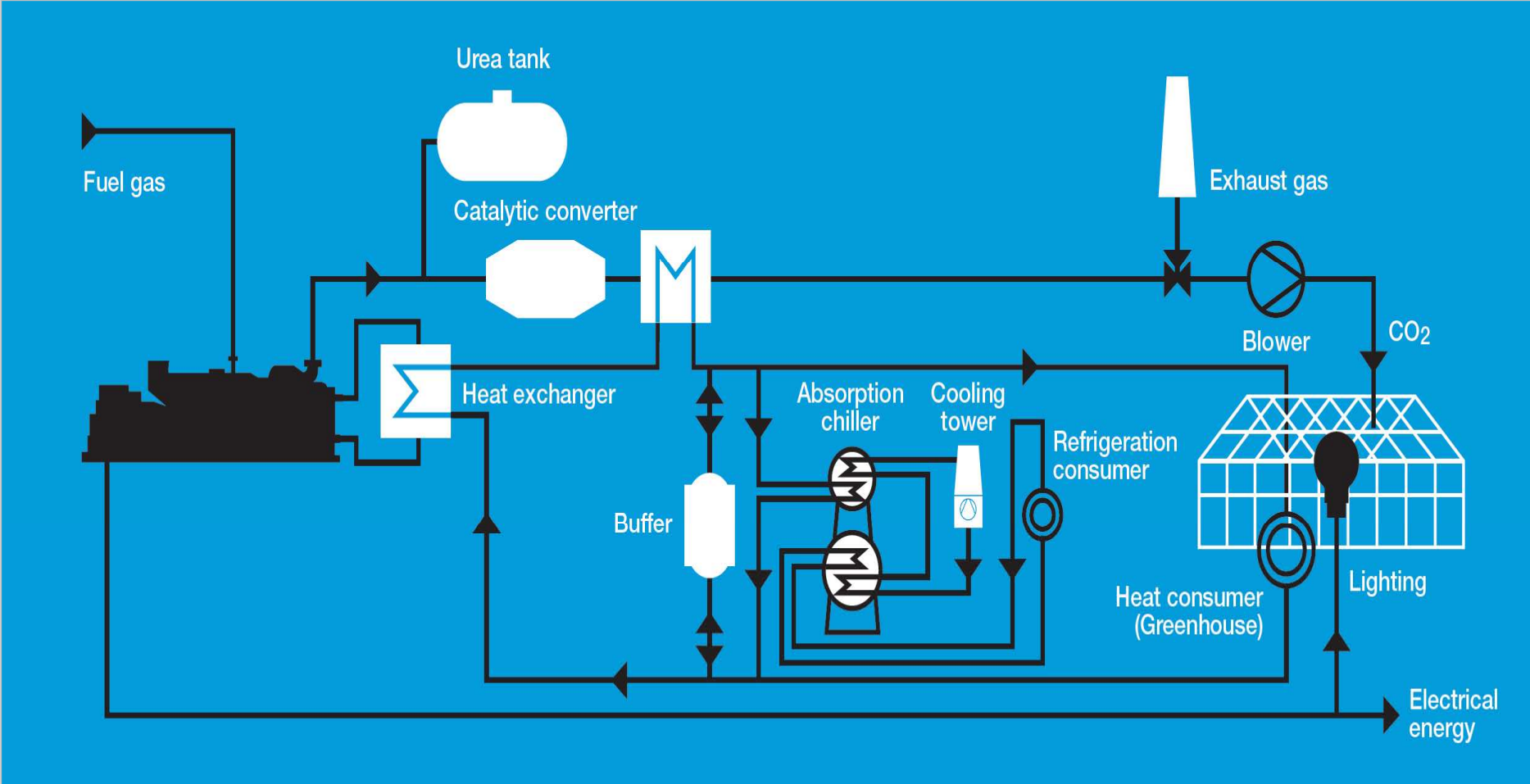

Module Control Cabinet



Modular System

Standard Layout

- 1 Exhaust gas cleaner
- 2 Exhaust gas cooler and condenser
- 3 Urea storage tank
- 4 Oil storage tank
- 5 Filter box
- 6 2nd silencer
- 7 CO₂ connection
- 8 Control panels
- 9 Connection to heating and gas
- 10 Exhaust gas stack 70 dba @ 1m
- 11 Ventilation ducts 70 dba @ 1m
- 12 Acoustical enclosure 75 dba @

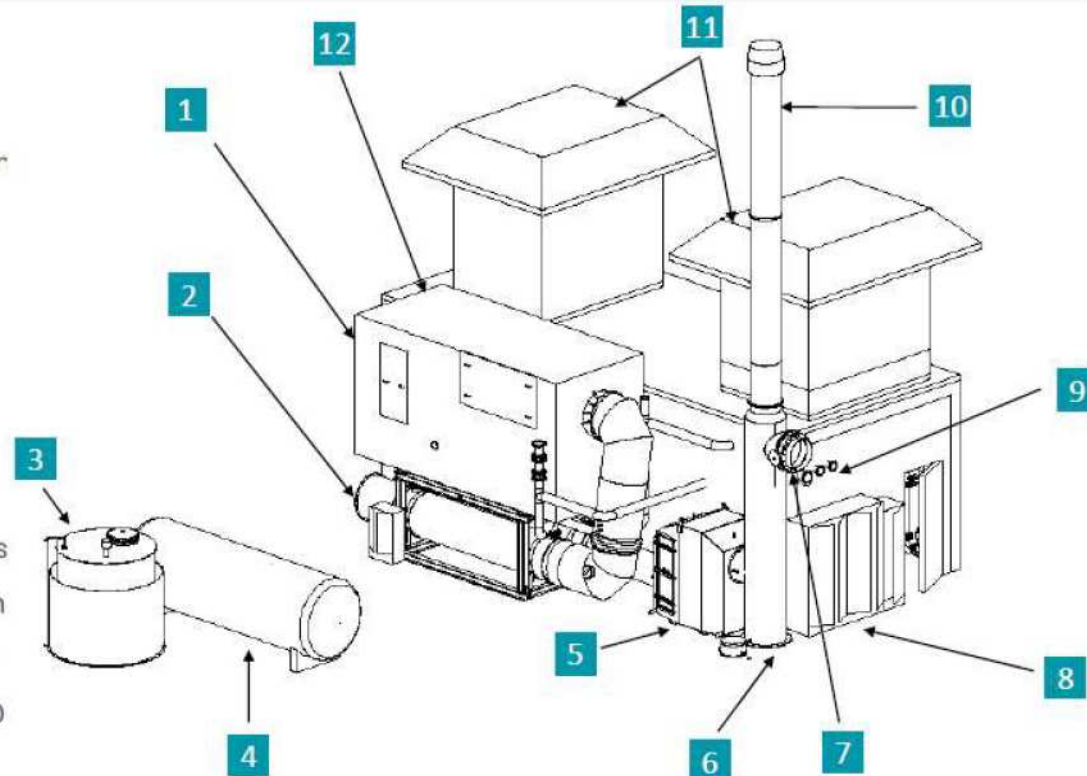

Custom build solution

Acoustic enclosure for indoor or for outdoor installations

Ventilation ducts 70 dba @) 1 m
Acoustical enclosure 70/75 dba @) 1 m



Custombuild solution

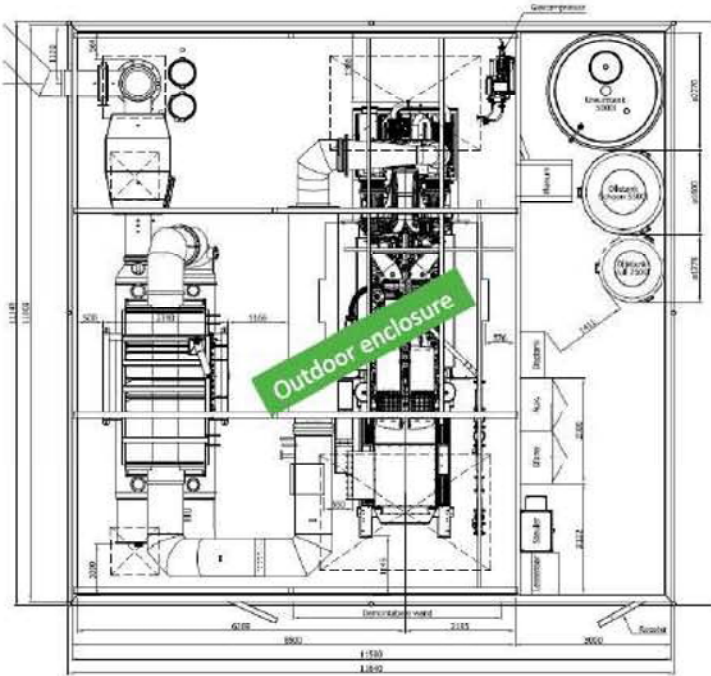
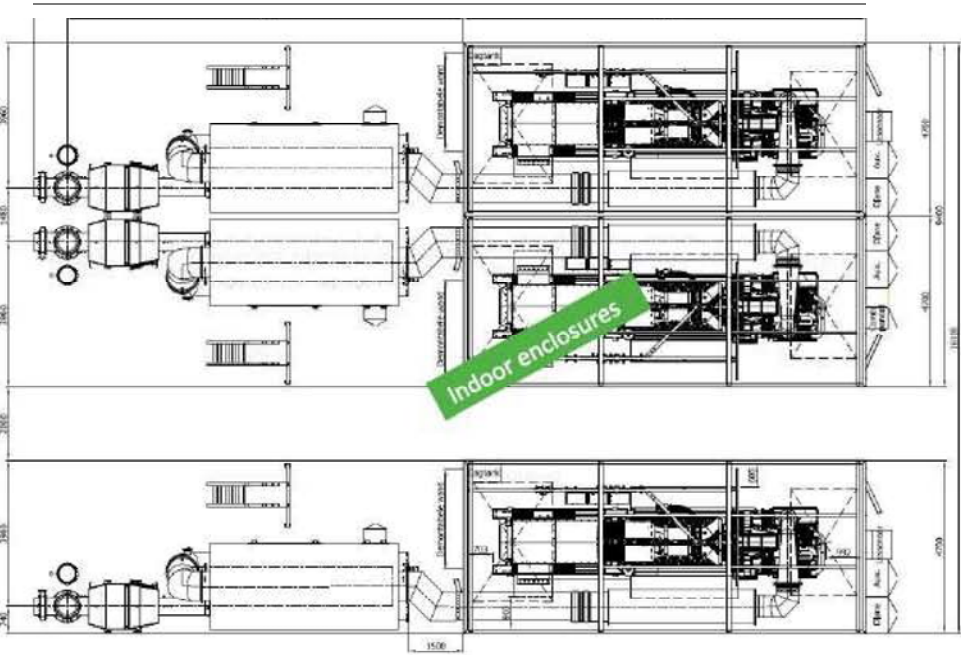

Complete lay-out drawings

P&ID's
Hydraulic diagrams
E-Drawings

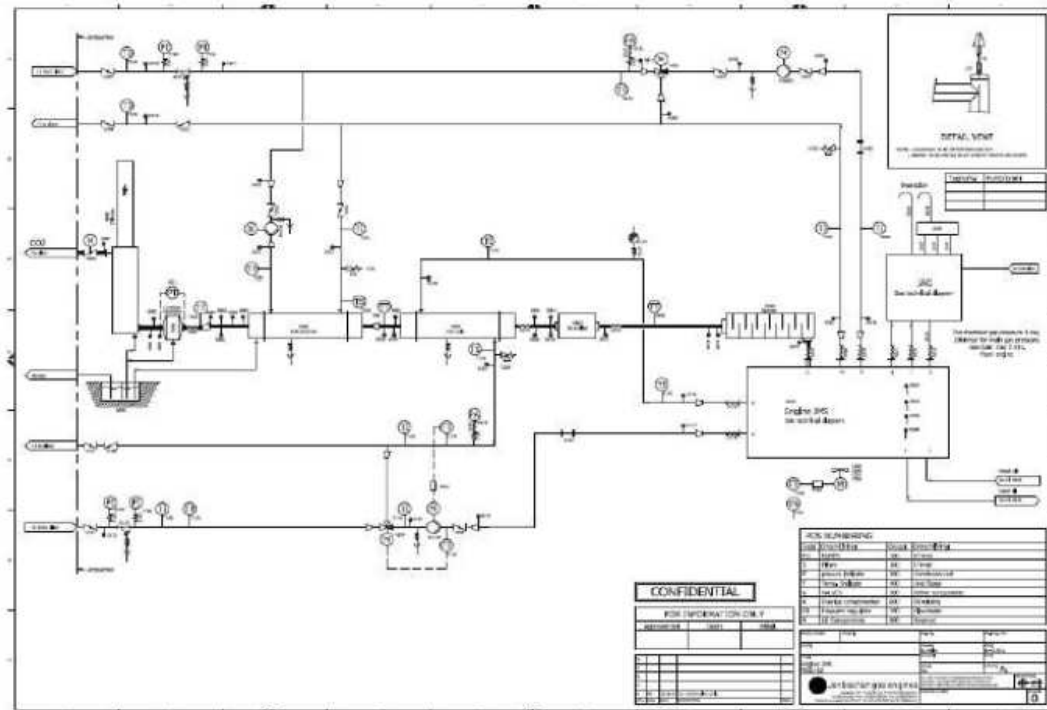

Example Project Economics: CA 2 MWe Grow Facility

- 2 MWe Combined Cooling & Power (“CCP”)
- 500 RT absorption (multi effect) chiller
- Grow Facility with 2000 x 1 kWe Grow Lights
- Capex \$2,785,483
- Opex \$302,898
- Energy Savings (CCP elec’ + cooling – fuel cost) **\$1,124,641**

	Yr 0	Yr 1	Yr 2	yr 3	yr 4	
Cost	-\$2,785,483.00	-\$302,898.00	-\$302,898.00	-\$302,898.00	-\$302,898.00	-\$3,997,075.00
Benefit		\$1,124,641.30	\$1,124,641.30	\$1,124,641.30	\$1,124,641.30	\$4,498,565.21

The Global Portfolio “a few references”

Clarke Energy has built 567 MWe of Grow house CHP installed in USA & Europe

Innio Jenbacher has built 2780 MWe of Grow house CHP in multiple countries (1320 engines)



Royal Pride AgriPort A7 Wieringermeer - The Netherlands

Greenhouse area 3 x 14.6 Ha



Energy Plant #1

6x 3MWe

5000M² Thermal Store

Energy Plant #2

6x 3MWe + 2x 4MWe

5000M² Thermal Store

Canada / USA

- Great Northern 12 MWe Leamington
- Houweling CA 13.2 MWe Los Angeles
- Hoosier Energy 13.2 MWe Indianapolis
- Houweling BC 8.8 MWe Vancouver
- Coldwater MI 13.2 MWe Coldwater



Den Berk Delice - Belgium

45 MWe of Grow house
CHP across 12 sites



Russia



Evrika	19 MWe	St. Petersburg
Krugly God	13.2 MWe	St. Petersburg
THK Roses	4 MWe	Volgograd
Mosroza	10.6 MWe	Moscow
Tyumen Agro	13.2 MWe	Tyumen
Lipetsk Agro	6.6 MWe	Lipetsk
Lukhovitski	19.8 MWe	Atapova
Vyborzhets	16 MWe	St. Petersburg
Moskovski	18 MWe	Moscow
Ovoshovod	8.8 MWe	Volgograd

United Kingdom



Cradle-to-Grave Delivery

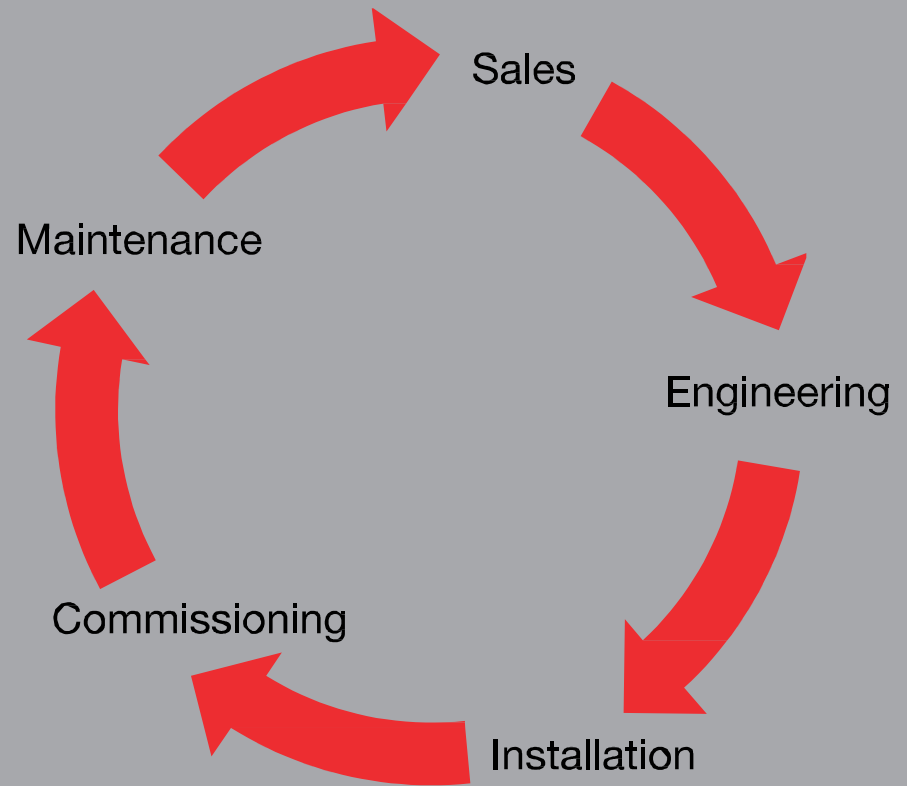

Maintenance Agreements

The flexibility to provide services which meet customer needs

- Comprehensive maintenance agreements (CSAs)
- Flexibility of term
- Commercial options regarding overhauls
- Availability / reliability guarantees
- Preventative maintenance only agreements
- Parts supply agreements

Predictable operating costs and risk mitigation through life

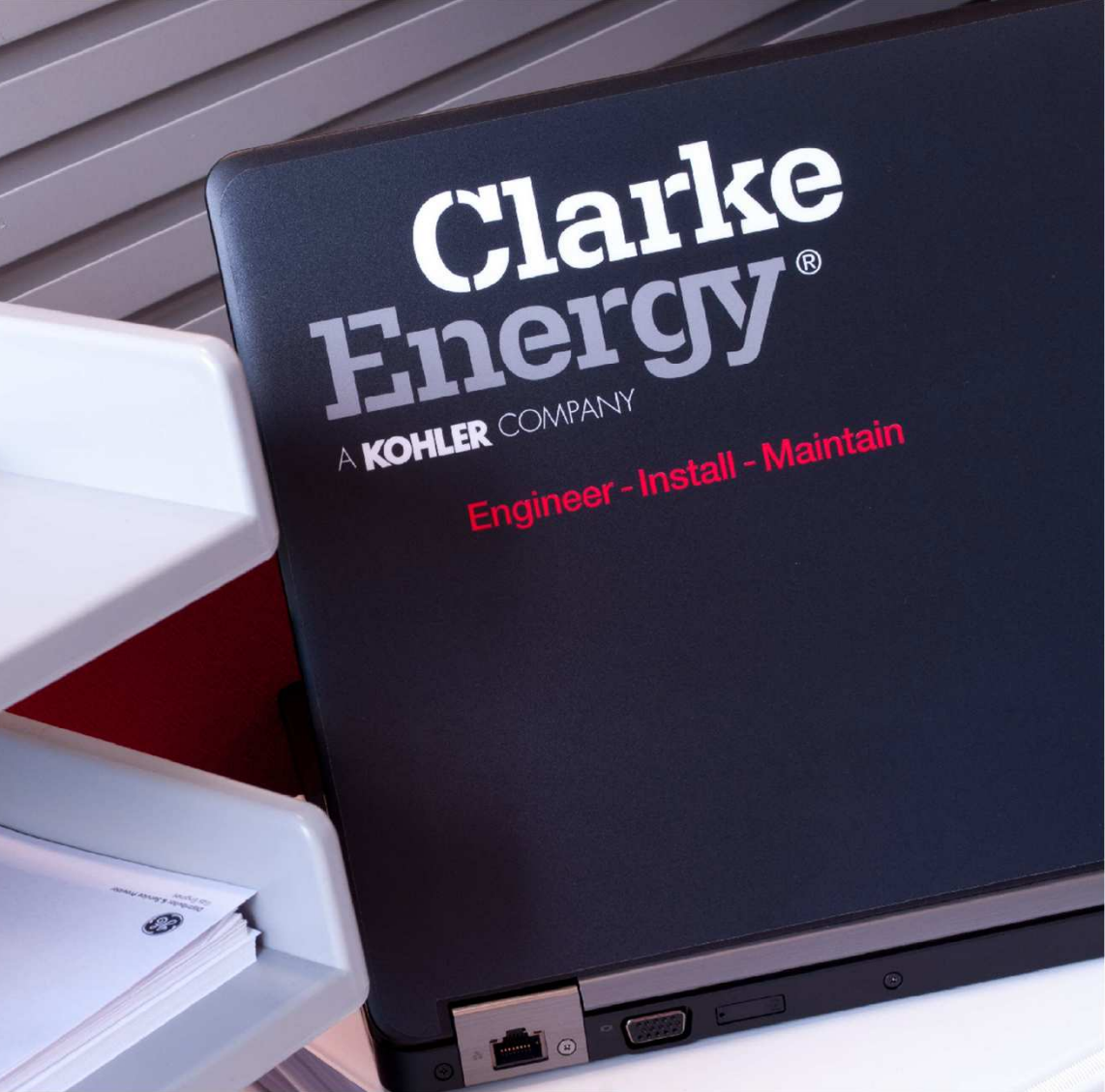

Clarke
Energy[®]
A KOHLER COMPANY

Engineer - Install - Maintain

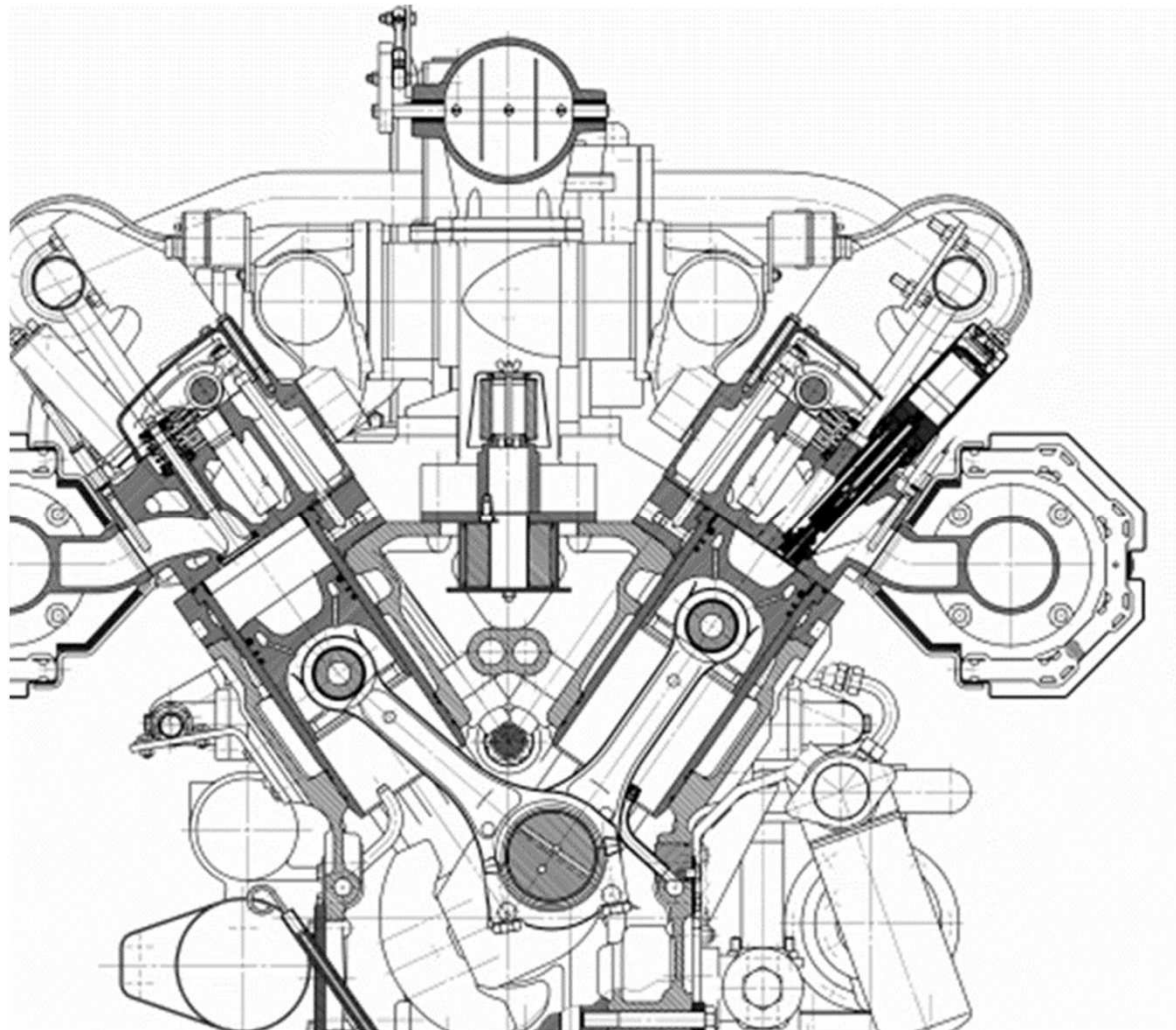

Contact

Clarke Energy USA
2100 Pewaukee
Road Waukesha
WI53188

262-565-5020

USA@clarke-energy.com